



Refrigeration Equipment

ICE MAKER

OEM/ODM PRODUCTION BASE



Ningbo Kaisong Electric Appliance Co., Ltd.



About us

- 01 Extensive Industry Expertise
- 02 Advanced R&D Capabilities
- 03 Quality and Certification Assurance

Ningbo Kaison Electric Appliance Co., Ltd., established in 1998, occupies an area of 15,000 square meters with a standard factory building covering 20,000 square meters. It is located in Cixi City, Zhejiang Province, renowned as the “hometown of home appliances.” The area benefits from well-established surrounding industries and convenient logistics and transportation.

The company has a strong foundation in the field of commercial refrigeration equipment, boasting 15 years of experience in ice maker production and 5 years in commercial kitchen freezer manufacturing. With a team of skilled refrigeration engineers and a fully equipped refrigeration laboratory, the company has achieved ISO9001, ISO14001, and ISO45001 certifications. Additionally, it holds multiple national patents and has obtained international certifications such as FCC, ETL, CE, and CB for various products.

With an annual production capacity of 80,000 ice machines, the company specializes in high-end custom commercial refrigeration equipment. All products are crafted using premium components and exquisite craftsmanship. As an OEM/ODM production base for several well-known brands, the company manufactures over 200 models of commercial refrigeration equipment, including ice makers, display cabinets, freezers, workbench freezers, and wine cabinets. These products generate an annual export value of \$3 million USD.

The products are widely used in catering, milk tea shops, bars, KTVs, supermarkets, convenience stores, and research laboratories. They are best-sellers in both domestic and international markets, consistently earning high praise from customers. We warmly

Welcome to negotiate and explore cooperation opportunities!



Ice Maker Series Features

1. Stainless Steel Shell: Elegant, easy to clean, and built for durability.
2. High-Quality Components: Featuring top-brand parts for extended lifespan, efficiency, and energy savings.
3. Food-Grade Ice Storage: Made with materials that meet national safety standards.
4. Intelligent Microcomputer Control: Simple operation with reliable safety features.
5. Copper-Nickel Composite Evaporator: Quick ice production, energy-efficient, corrosion-resistant, and time-saving.

Snowflake Granular Ice

Flake Ice Machine

Cube Ice Making Machine

Crescent Ice Making Machine

Customization of Special Ice Shapes

CUBE ICE MAKING MACHINE SERIES



Model	AP-25BT
Ice production/24H:	25Kg
Ice storage:	2.5Kg
Power:	200W
Cooling way:	Air-cooled
G.W/N.W:	22Kg/20Kg
Product size:	360x440x450mm
Packing size:	385x460x530mm

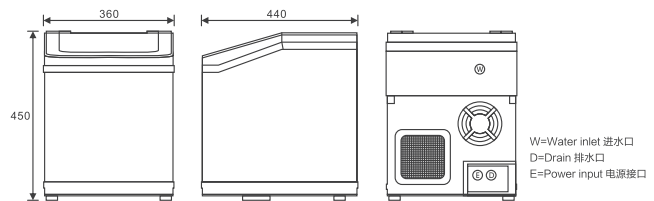

Model	KT-27	KT-36
Ice production/24H:	28Kg	35Kg
Ice storage:	8Kg	8Kg
Power:	170W	190W
Cooling way:	Air-cooled	Air-cooled
G.W/N.W:	18.5Kg/16Kg	19Kg/16.5Kg
Product size:	345x330x620mm	345x330x620mm
Packing size:	390x385x645mm	390x385x645mm

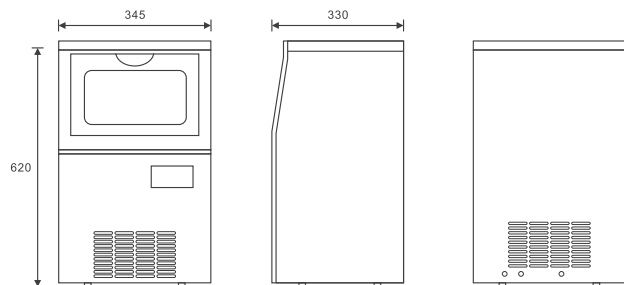

CUBE ICE MAKING MACHINE SERIES



Model	KN-40	KN-50
Ice production/24H:	40Kg	50Kg
Ice storage:	10Kg	10Kg
Power:	180W	245W
Cooling way:	Air-cooled	Air-cooled
G.W/N.W:	23Kg/21.5Kg	23.5Kg/22Kg
Product size:	385x400x720mm	385x400x720mm
Packing size:	445x475x775mm	445x475x775mm

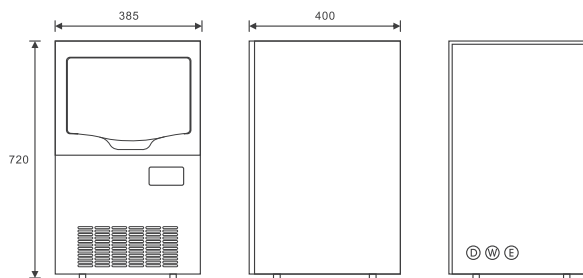

Model	KS-36	KS-50
Ice production/24H:	40Kg	50Kg
Ice storage:	12Kg	12Kg
Power:	200W	245W
Cooling way:	Air-cooled	Air-cooled
G.W/N.W:	24Kg/21Kg	27Kg/25Kg
Product size:	450x405x750mm	450x405x750mm
Packing size:	505x460x815mm	505x460x815mm

Model	KS-60
Ice production/24H:	60Kg
Ice storage:	12Kg
Power:	275W
Cooling way:	Air-cooled
G.W/N.W:	29Kg/26Kg
Product size:	450x405x750mm
Packing size:	505x460x815mm

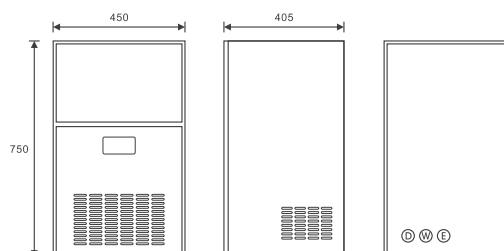

CUBE ICE MAKING MACHINE SERIES



Model	KX-65
Ice production/24H:	70Kg
Ice storage:	15Kg
Power:	300W
Cooling way:	Air-cooled
G.W/N.W:	29Kg/27Kg
Product size:	480x450x780mm
Packing size:	540x515x815mm

Model	KX-78
Ice production/24H:	80Kg
Ice storage:	15Kg
Power:	380W
Cooling way:	Air-cooled
G.W/N.W:	30Kg/28Kg
Product size:	480x450x780mm
Packing size:	540x515x815mm

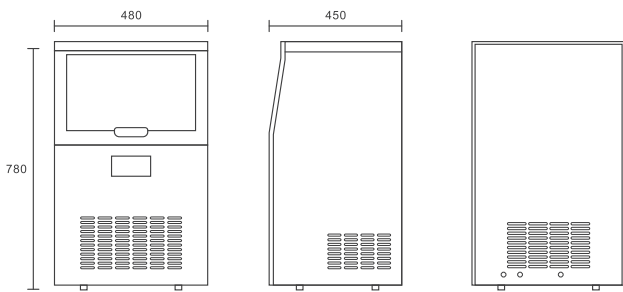

Model	KM-78	KM-90
Ice production/24H:	78Kg	90Kg
Ice storage:	20Kg	20Kg
Power:	380W	455W
Cooling way:	Air-cooled	Air-cooled
G.W/N.W:	36Kg/33Kg	37Kg/35Kg
Product size:	515x570x785mm	515x570x785mm
Packing size:	550x600x830mm	550x600x830mm

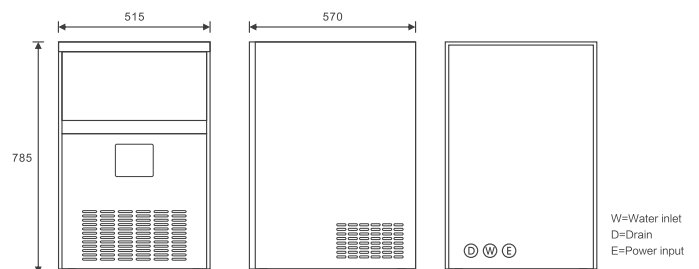

CUBE ICE MAKING MACHINE SERIES



Model	KMH-78	KMH-90
Ice production/24H:	80Kg	90Kg
Ice storage:	20Kg	20Kg
Power:	380W	455W
Cooling way:	Air-cooled	Air-cooled
G.W/N.W:	29Kg/26Kg	31Kg/28Kg
Product size:	515x450x830mm	515x450x830mm
Packing size:	565x515x845mm	565x515x845mm

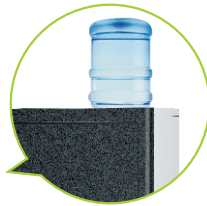
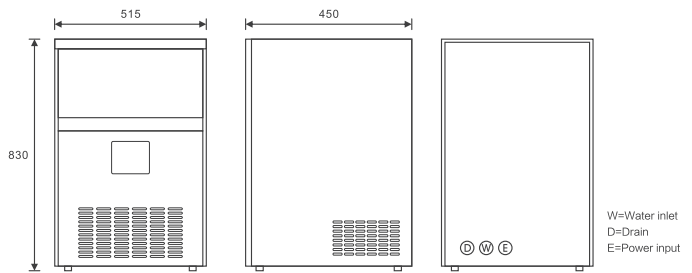

Model	AP-100P	AP-150P
Ice production/24H:	60Kg	80Kg
Ice storage:	12Kg	12Kg
Power:	300W	340W
Cooling way:	Air-cooled	Air-cooled
G.W/N.W:	31Kg/28Kg	43Kg/40Kg
Product size:	510x450x820mm	510x450x820mm
Packing size:	560x490x830mm	560x490x830mm

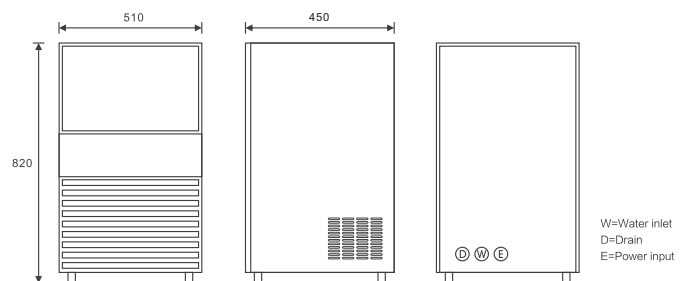

CUBE ICE MAKING MACHINE SERIES



Model	AP-180P
Ice production/24H:	100Kg
Ice storage:	45Kg
Power:	375W
Cooling way:	Air-cooled
G.W/N.W:	47Kg/43Kg
Product size:	660x680x915mm
Packing size:	755x725x915mm

Model	AP-220P
Ice production/24H:	120Kg
Ice storage:	45Kg
Power:	465W
Cooling way:	Air-cooled
G.W/N.W:	48Kg/44Kg
Product size:	660x680x915mm
Packing size:	755x725x915mm

Model	AP-260P
Ice production/24H:	140Kg
Ice storage:	45Kg
Power:	500W
Cooling way:	Air-cooled
G.W/N.W:	49Kg/45Kg
Product size:	660x680x915mm
Packing size:	755x725x915mm

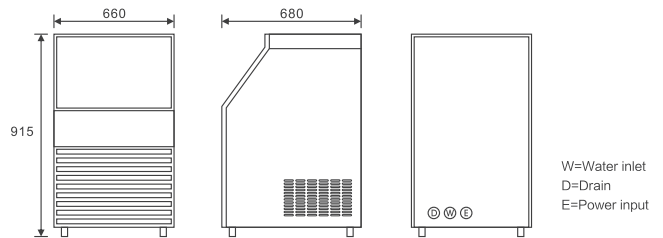

CUBE ICE MAKING MACHINE SERIES



Model	AP-300P	AP-350P
Ice production/24H:	200Kg	250Kg
Ice storage:	140Kg	140Kg
Power:	800W	855W
Cooling way:	Air-cooled /Water-cooled	Air-cooled /Water-cooled
G.W/N.W:	80Kg/73Kg	81Kg/74Kg
Product size:	560x830x1570mm	
Packing size:	625x645x635mm (Mainframe) 880x640x990mm (Ice Storage bin)	

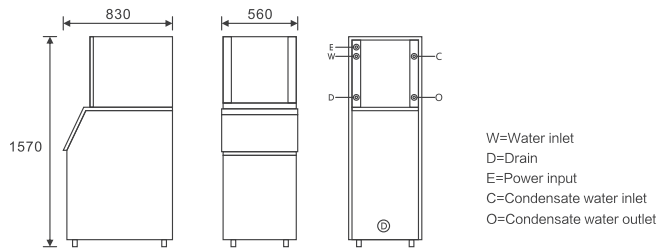

Model	AP-500P
Ice production/24H:	300Kg
Ice storage:	140Kg
Power:	945W
Cooling way:	Air-cooled /Water-cooled
G.W/N.W:	88Kg/82Kg
Product size:	560x830x1700mm
Packing size:	625x645x790mm (Mainframe) 880x640x990mm (Ice Storage bin)

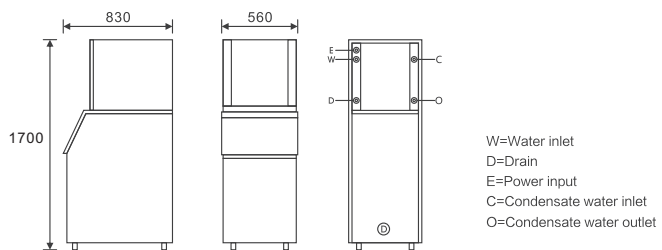

CUBE ICE MAKING MACHINE SERIES



Model	AP-600P
Ice production/24H:	350Kg
Ice storage:	200Kg
Power:	970W
Cooling way:	Air-cooled / Water-cooled
G.W/N.W:	100Kg/92Kg
Product size:	760x850x1650mm
Packing size:	700x845x635mm (Mainframe) 915x845x1045mm(Ice Storage bin)

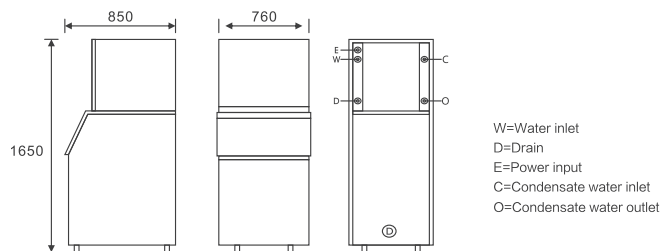

Model	AP-800P	AP-1000P
Ice production/24H:	400Kg	500Kg
Ice storage:	200Kg	200Kg
Power:	1210W	1870W
Cooling way:	Air-cooled / Water-cooled	Air-cooled / Water-cooled
G.W/N.W:	120Kg/110Kg	125Kg/115Kg
Product size:	760x850x1850mm	
Packing size:	700x845x825mm (Mainframe) 915x845x1045mm (Ice Storage bin)	

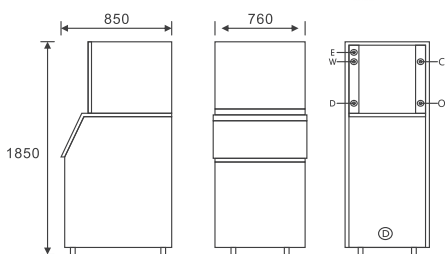

Model	AP-1300P
Ice production/24H:	600Kg
Ice storage:	200Kg
Power:	1900W
Cooling way:	Air-cooled / Water-cooled
G.W/N.W:	130Kg/120Kg
Product size:	760x850x1850mm
Packing size:	700x845x825mm (Mainframe) 915x845x1045mm(Ice Storage bin)

CUBE ICE MAKING MACHINE SERIES

Model	AP- 1500P	AP- 2000P
Ice production/24H:	1000Kg	1200Kg
Ice storage:	455Kg	455Kg
Power:	2000W	3400W(380V)
Cooling way:	Air-cooled /Water-cooled	Air-cooled /Water-cooled
G.W/N.W:	180Kg/ 165Kg	190Kg/ 175Kg
Product size:	1230x960x2000mm	
Packing size:	1285x670x900mm (Mainframe) 1280x970x1170mm (Ice Storage bin)	

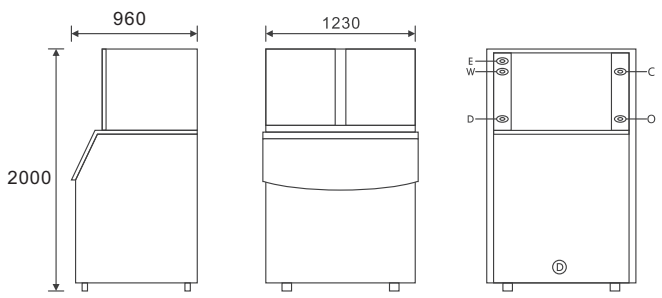

W=Water inlet
D=Drain
E=Power input
C=Condensate water inlet
O=Condensate water outlet





Features of Snowflake Granular Ice

- **Advanced Automated Control System:** Equipped with a computerized automatic control system to ensure seamless machine operation, self-diagnostics, and enhanced stability. This system also simplifies maintenance and servicing.
- **Rotary Ice-Making Technology:** Utilizes a rotating extrusion mechanism for efficient ice production. This method eliminates the need for separate ice releasing and crushing processes, saving time and energy while significantly reducing the cost of ice production.
- **Compact and Versatile Granular Ice:** The small and refined granular ice penetrates narrow gaps, enabling rapid cooling. Its soft texture is easy to chew, enhancing taste and freshness for a wide range of applications.
- **Diverse Applications:** Ideal for seafood displays, hot pot restaurants, Japanese cuisine establishments, and wine or champagne buckets. Additionally, it is widely used in medical and laboratory environments.

SNOWFLAKE GRANULAR ICE SERIES



Model	KL-30
Ice production/24H:	30Kg
Ice storage:	12Kg
Power:	195W
Cooling way:	Air-cooled
G.W/N.W:	25.5Kg/23.5Kg
Product size:	340x455x620mm
Packing size:	385x500x700mm

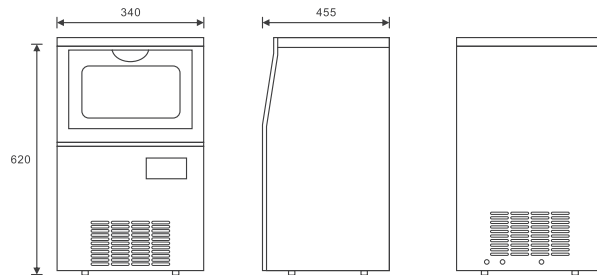

Model	KL-45
Ice production/24H:	45Kg
Ice storage:	15Kg
Power:	215W
Cooling way:	Air-cooled
G.W/N.W:	32Kg/27.5Kg
Product size:	385x523x720mm
Packing size:	425x565x775mm

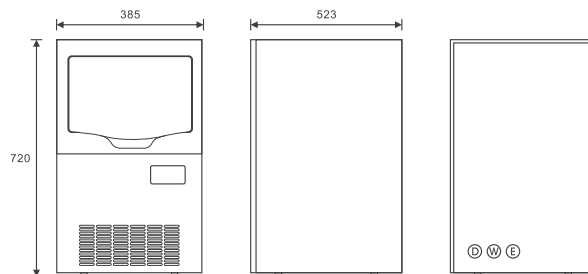

SNOWFLAKE GRANULAR ICE SERIES



Model	KL-60	KL-80
Ice production/24H:	60Kg	80Kg
Ice storage:	30Kg	30Kg
Power:	320W	340W
Cooling way:	Air-cooled	Air-cooled
G.W/N.W:	42Kg/36Kg	42Kg/36Kg
Product size:	450x570x750mm	450x570x750mm
Packing size:	505x625x815mm	505x625x815mm

Model	KL-100	KL-120
Ice production/24H:	100Kg	120Kg
Ice storage:	30Kg	30Kg
Power:	560W	580W
Cooling way:	Air-cooled	Air-cooled
G.W/N.W:	51Kg/46Kg	52Kg/48Kg
Product size:	515x615x830mm	515x615x830mm
Packing size:	565x680x845mm	565x680x845mm

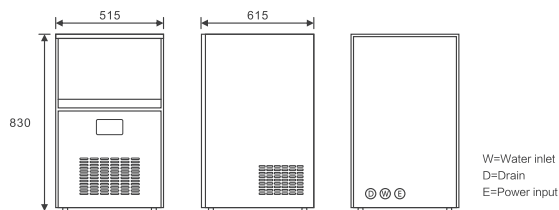

Model	KL-150	KL-200
Ice production/24H:	150Kg	200Kg
Ice storage:	70Kg	70Kg
Power:	620W	630W
Cooling way:	Air-cooled	Air-cooled
G.W/N.W:	72Kg/68Kg	73Kg/69Kg
Product size:	660x835x1080mm	660x835x1080mm
Packing size:	725x915x1160mm	725x915x1160mm

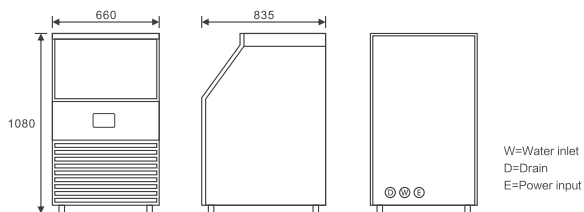

SNOWFLAKE GRANULAR ICE SERIES



Model	KL-280	KL-350
Ice production/24H:	280Kg	350Kg
Ice storage:	140Kg	140Kg
Power:	960W	1280W
Cooling way:	Water-cooled	Water-cooled
G.W/N.W:	98Kg/90Kg	100Kg/92Kg
Product size:	560x830x1570mm	
Packing size:	625x645x635mm (Mainframe)	
	880x640x990mm (Ice Storage bin)	

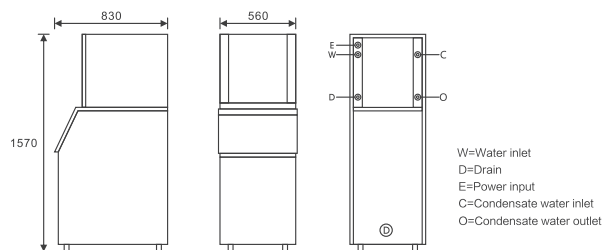

Model	KL-500	KL-650
Ice production/24H:	500Kg	650Kg
Ice storage:	200Kg	200Kg
Power:	2860W	2900W
Cooling way:	Water-cooled	Water-cooled
G.W/N.W:	142Kg/133Kg	147Kg/138Kg
Product size:	760x850x1850mm	
Packing size:	700x845x825mm (Mainframe)	
	915x845x1045mm (Ice Storage bin)	

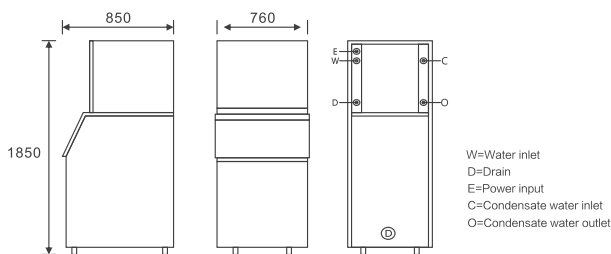

CRESCENTICE MACHINE SERIES

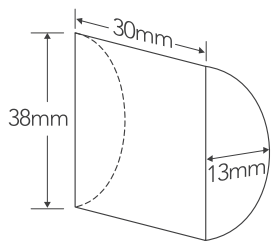

Weight: 8g
Water content: 2%

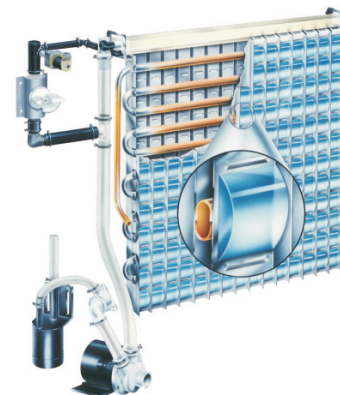

Features of Crescent Ice

- Crystal-Clear, Bubble-Free Design: Crescent ice boasts a transparent, bubble-free appearance that prevents clumping. It quickly cools beverages while adding an elegant visual appeal.

- Advanced Automated Control System: Equipped with a computerized automatic control system to ensure seamless machine operation, self-diagnostics, and enhanced stability. This system also simplifies maintenance and servicing.

- Durable Stainless Steel Ice Tray: Made entirely of stainless steel, the ice tray resists the effects of hard water or high mineral content, minimizing scale buildup. This ensures the ice remains hygienic and maintains its quality while reducing machine maintenance costs.

- Dual-Sided Flow Ice-Making: Features a vertical ice tray with water flowing over both sides to form ice cubes. This innovative design doubles efficiency by freezing water in a single flow cycle, conserving both water and energy.



Model	KY-30	KY-60
Ice production/24H:	30Kg	60Kg
Ice storage:	15Kg	15Kg
Power:	320W	370W
Cooling way:	Air-cooled	Air-cooled
G.W/N.W:	31Kg/28Kg	34Kg/31Kg
Product size:	515x450x830mm	515x570x785mm
Packing size:	565x515x845mm	615x565x830mm

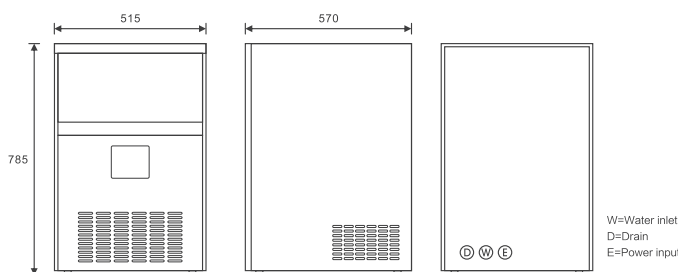

CRESCENTICE MACHINE SERIES



Model	KY-80	KY-120
Ice production/24H:	80Kg	120Kg
Ice storage:	60Kg	60Kg
Power:	495W	630W
Cooling way:	Air-cooled	Air-cooled
G.W/N.W:	64Kg/60Kg	67Kg/63Kg
Product size:	660x680x1080mm	660x680x1080mm
Packing size:	725x755x1160mm	725x755x1160mm

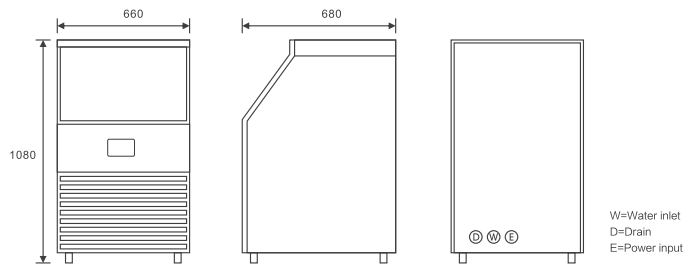

Model	KY-160	KY-220
Ice production/24H:	160Kg	220Kg
Ice storage:	140Kg	140Kg
Power:	1000W	1125W
Cooling way:	Water-cooled	Water-cooled
G.W/N.W:	94Kg/86Kg	97Kg/89Kg
Product size:	560x830x1770mm	
Packing size:	625x645x825mm (Mainframe) 880x640x990mm (Ice Storage bin)	

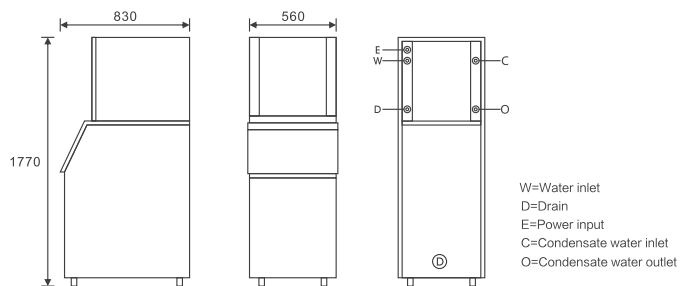

CRESCENTICE MACHINE SERIES



Model	KY-260	KY-320
Ice production/24H:	260Kg	320Kg
Ice storage:	200Kg	200Kg
Power:	1300W	1815W
Cooling way:	Water-cooled	Water-cooled
G.W/N.W:	120Kg/ 110Kg	125Kg/ 115Kg
Product size:	760x850x1850mm	
Packing size:	700x845x825mm (Mainframe)	
	915x845x1045mm (Ice Storage bin)	

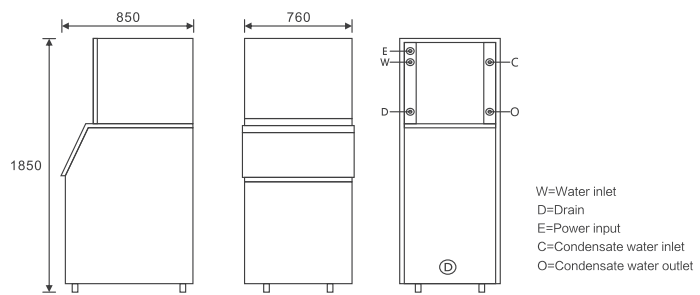

Requirements for ice making machine operation

- Ambient temperature: 2~43°C
- Water inlet temperature: 2~38°C
- Water pressure: 0.13MPa~0.55MPa
- Condensing method: air-cooled or water-cooled

Installation space requirements

- The top and sides of the machine should be at least 25cm away from the wall, the back should be at least 12cm away, and there should be no obstruction at the air outlet of the air-cooled type.

24-hour maximum ice production test conditions

- Room temperature 20°C, water temperature 10°C

FLAKE ICE MACHINE SERIES

Features of Flake Ice

- Flake ice is formed at the lowest temperature, with less than 2% water content, extremely dry, not easily melted, and has a longer freshness preservation time.
- The evaporator is made of 304 stainless steel material, formed in one piece, and has a low failure rate.
- Flake ice is composed of irregular ice flakes with adjustable thickness of 1-2mm. It is suitable for industrial, fish, seafood product displays, logistic transportation, flour mixing and cooling, and other applications.



Model	KP-200	KP-300
Ice production/24H:	200Kg	300Kg
Ice storage:	140Kg	200Kg
Power:	1500W	1760W
Cooling way:	Air-cooled	Air-cooled
G.W/N.W:	126Kg/ 118Kg	159Kg/ 144Kg
Product size:	580x830x1540mm	780x850x1795mm
Packing size:	780x850x765mm (Mainframe) 915x845x1045mm (Ice Storage bin)	

Model	KP-500
Ice production/24H:	500Kg
Ice storage:	200Kg
Power:	3170W
Cooling way:	Air-cooled
G.W/N.W:	168Kg/ 153Kg
Product size:	780x850x1795mm
Packing size:	780x850x765mm (Mainframe) 915x845x1045mm (Ice Storage bin)

FLAKE ICE MACHINE SERIES



Model	KP-1T
Ice production/24H:	1000Kg
Ice storage:	500Kg
Voltage/Frequency:	3P/380V/50Hz
Power:	4.1KW
Cooling way:	Air-cooled
G.W/N.W:	247Kg
Product size:	1220x1180x1900mm
Packing size:	1210x800x900mm (Mainframe) 1210x1180x1000mm (Ice Storage bin)

Model	KP-1.5T
Ice production/24H:	1500Kg
Ice storage:	500Kg
Voltage/Frequency:	3P/380V/50Hz
Power:	6.53KW
Cooling way:	Air-cooled
G.W/N.W:	360Kg
Product size:	1320x1250x2100mm
Packing size:	1320x970x1000mm (Mainframe) 1320x1250x1100mm (Ice Storage bin)

Model	KP-3T
Ice production/24H:	3000Kg
Ice storage:	1000Kg
Voltage/Frequency:	3P/380V/50Hz
Power:	10.17KW
Cooling way:	Air-cooled
G.W/N.W:	590Kg
Product size:	1600x1380x2600mm
Packing size:	1600x1300x1300mm (Mainframe) 1600x1380x1300mm (Ice Storage bin)

Model	KP-2T
Ice production/24H:	2000Kg
Ice storage:	600Kg
Voltage/Frequency:	3P/380V/50Hz
Power:	8KW
Cooling way:	Air-cooled
G.W/N.W:	487Kg
Product size:	1500x1380x2400mm
Packing size:	1500x1095x1100mm (Mainframe) 1500x1380x1300mm (Ice Storage bin)

Flake ice machine evaporator structure

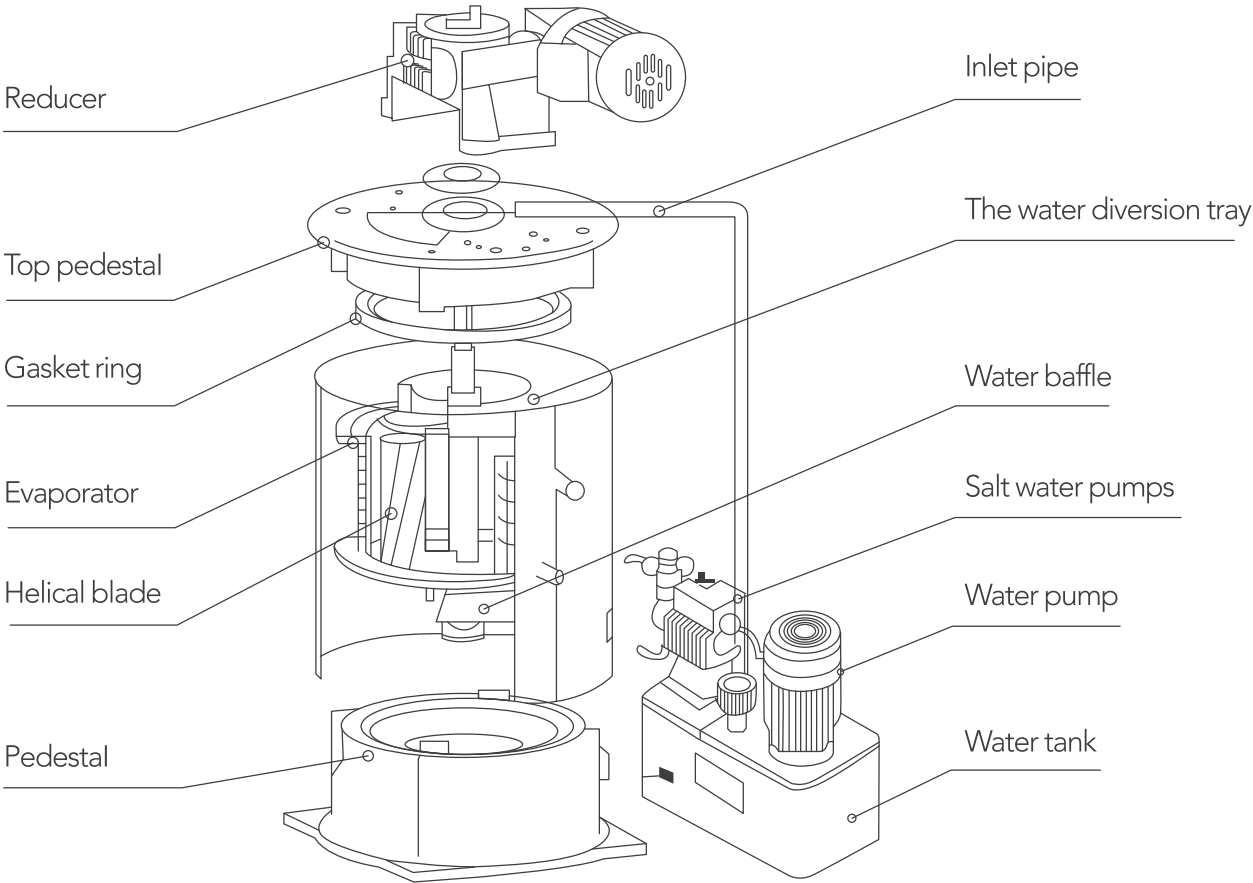

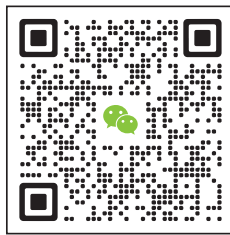

Brun[®]
贝林

Ningbo Kaison Electrical Appliance Co., Ltd

Address: No. 83 Huatang Road, Fuhai town, cixi city Ningbo

Contact: Andy Wang Mobile: 0086-18957458068

Email: andywang@nbkaison.com

Website: <https://www.kaisonfreezer.com>